



MyDefender Mobile Hand Washing Station Spec Sheet

Top

- Counter Top Construction - High pressure laminate top constructed of 5/8" particle board with a phenolic backer.
- Edge Material – color matched PVC.
- Laminate Options – Merino® standard high-pressure laminates with AB+ antibacterial laminate on the counter and cabinet. Custom graphics and logos also available at an upcharge. Standard top color laminate selections in stock are White or Black countertops. AB+ laminate in any color, allow for an extended lead time.

Cabinet & Frame

- Available in 26" high and 34" high. (32" wide, 25.5" deep)
- Construction – High pressure laminate sides and doors constructed of 3/4" particle board. Standard cabinet laminate selection in stock is Slate Grey.
- Casters - Four 3" casters. Two casters swivel with ability to lock. Two are non-swivel. Locking casters are on the side in order to push in narrowest position to fit in doorways.
- Locking door with key.
- Indoor or outdoor version available.

Components

- Sink – Stainless steel square sink 15" x 15" x 6" with faucet.
- Water Containers – One 5 gallon container for fresh water. Suggested fill in fresh water container is at 4.75 gallons for the 34" unit, 3.75 gallons for the 26" unit. One 5 gallon container for waste water.
- Pump – Flow rate is a 1/2 gallon per minute.
 - Pump is a compact, self-priming pump that has been adjusted to run on battery power. 1/2 gallon per minute allows it to pump at a speed of time. With a pump and tank operating together, 4 - 5 gallons of water will be pumped at 12-15 minutes total to drain a tank when running consistently.
 - The faucet used on the battery option has one handle, one line for cold water.
 - The faucet used on the corded option has two handles, one line for cold water, one line for hot water.
 - The pump on the plug-in option is different from the battery option.
 - The plug-in option has heat, and the heater is corded. The water pump is also corded.
- Power – Rechargeable 20V battery powered option. Includes two 20V lithium ion batteries and one charger. The battery charges much like your at home power tools. The battery needs to be completely removed from the hand washing station to be charged. Battery life will be based on how your hand washing practices are maintained. The battery on average will last up to 4-6 hours of **consistent** hand washing. Washing your hands at 20 seconds per handwash estimates 500+ handwashes in an 8 hour time frame.

OR

MyDefender Mobile Hand Washing Station
Spec Sheet 11022020



- Power – Plug-in option. Water heater add on option for plug in only.
- You will need to have unit plugged into a grounded and dedicated 120V, 20A outlet.
- Hand Washes – For the 34” high unit, running the water for 15 – 20 seconds (5 – 10 seconds for wet of hands and 5 – 10 seconds for rinse of hands) with a tank fill at 4.75 gallons, results in about 45 hand washes. For the 26” high unit, running the water for 15 – 20 seconds (5 – 10 seconds for the wet of hands and 5 – 10 seconds for the rinse of hands) with a tank fill at 3.75 gallons, results in about 33 hand washes. *(Note: It is recommended to turn water off and soap hands to get the most use out of a water tank based on data above.)*

ADA

- The faucet meets ADA Guidelines and ANSI A117.1 requirement for accessible and usable building facilities. Check your local codes.

NSF

- All plumbing components inside the unit are NSF certified.

CE

- The pump in the battery unit is CE certified.
- The pump in the plug-in option is UL listed.

FDA

- The polypropylene fresh water and waste water tanks meet the FDA regulation 21 CFR 177.1520. This regulation allows use of the olefin polymer in “...articles or components pf articles intended for use in contact with food...” Specific limitations may apply.

Warranty – 1 year limited warranty.

See Operation Manual for Proper & Safe Operation

Made in the USA

Hand Washing Station Dimensions and Weights.

Description	Overall Product Dims	Product Weight	Shipping Dims	Shipping Weight
34” High Hand Washing Station	34” H x 25.5” W x 32” L	110 lbs Equipped (plus one full tank add 45 lbs)	34” H x 25.5” W x 32” L	155 lbs
26” High Hand Washing Station	26” H x 25.5” W x 32” L	95 lbs Equipped (plus one full tank add 45 lbs)	26” H x 25.5” W x 32” L	135 lbs

Hand Washing Station 34" High Dimensions

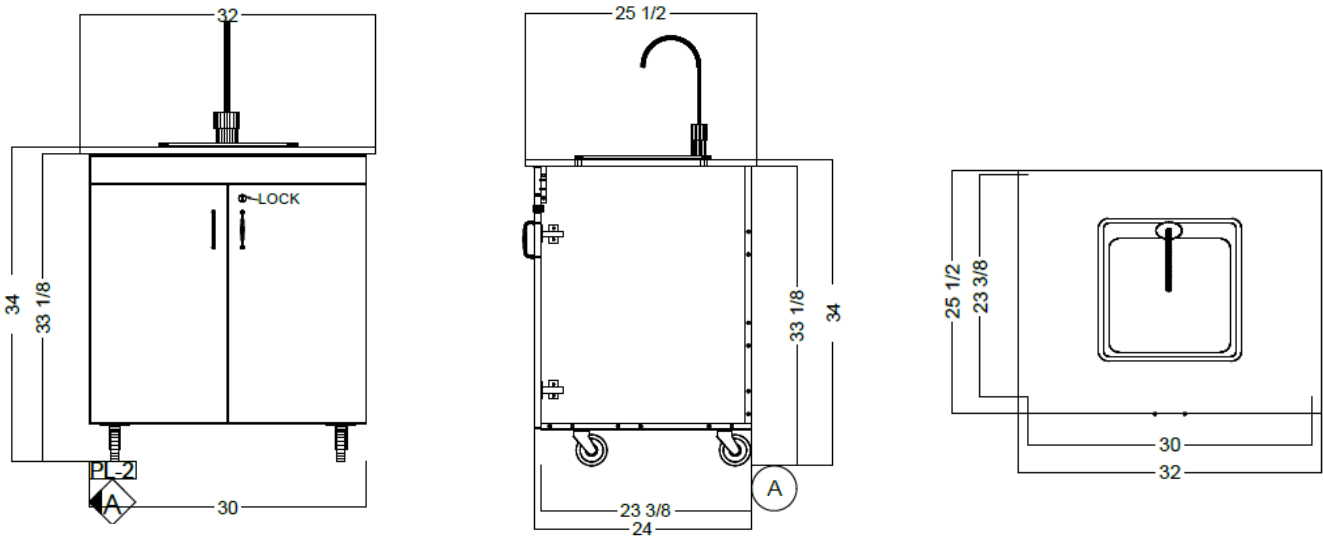

Hand Washing Station 26" High Dimensions

